



Public Art in Community Spaces: participatory processes towards co creation and co-ownership.

Trinity Session Case Study:

Diepsloot: I love you; I love you not. Artworks programme for the Diepsloot, Extension 2, public environment upgrade. 2011-2012.

Commissioned by the City of Johannesburg, implemented by the Johannesburg Development Agency.

Curated and Coordinated by the Trinity Session in collaboration with the Diepsloot Arts and Culture Network and Sticky Situations.



Diepsloot project area and proposed locations for public artwork

CONTEXT

As part of a 3-year contract with the City of Johannesburg to curate and coordinate public art programmes for a series of upgrade areas in the greater Johannesburg metro area, the *Diepsloot: I love you, I love you not.* programme demonstrates the logics of co-production and co-authorship through strategic creative collaborative involving the participation of local stakeholders; small businesses, community groups, and city departments.

The artworks programme was phased over two years in accordance with the upgrade programme. The Trinity Session's appointment was finalised 6 months into the first financial year of the upgrade (2010-2011) leaving six months to research and develop a curatorial strategy for implementation. Work thus commenced with the surveying of potential sites and collaborators near the upgrade area.

ORIENTATION

Integral to this research period was the identification of key players within the community who could assist with public reach, creative exchanges and educational and training opportunities. Initial meetings took place in Johannesburg with 2610 South Architects the urban designers appointed to the upgrading of the Taxi Rank and adjacent public realm. 2610 South Architects in turn introduced The Trinity Session to Sticky Situations a dynamic organization which had been working on the ground for some time in the area; facilitating various solutions around service delivery in the township. In turn The Trinity Session was introduced to the Diepsloot Arts and Culture Network (DACN) a collective of multi-skilled performance artists whose networks extended to a range of other community-based organisations including recyclers, semi-skilled and skilled trades people, and so forth.

CHALLENGES AND OPPORTUNITIES: TURNING POLICY CONSTRAINTS AND DEADLINES TO THE PROJECT AND CLIENTS ADVANTAGE.

Neither the budget nor the 6-month time frame afforded, in the first phase of the programme was sufficient to produce a tangible, piece of public art. In addition, the % for Public Art Policy within in the City of Johannesburg, prioritises capital expenditure over operational expenditure. These constraints indicated that we should rather motivate for a more intensive process of social interaction and engagement with various players within the upgrade area in the first phase and use this period to develop a series of conceptual designs that would form the basis for a final design and build programme that would unfold in the following financial year.

STRATEGIC PARTNERSHIPS

The DACN's annual festival and parade was an important point of focus for the organization at the time of meeting them, yet they had limited funds for their June 2011 festival, hence we entered into a strategic creative partnership, where their social reach within the community could assist in identifying a variety of participants as well as creative solutions for the research and design phase of the artworks programme; which in turn would feed the creative workshop process required to generate the narrative, look and feel and potential spatial impact of the piece of public art imagined for the site. The parade would thus become an all-encompassing research, design and documentation tool, to facilitate community participation and buy in and media interest for the artworks programme, and provide the necessary creative content to inform the implementation plan for the making of the sculpture in the next financial year.

ANCHOR TENANTS AND SITE CHARACTERISTICS

Relative to the sites suggested by City for artistic interventions in the upgrade area, the Muzomuhle Primary School located along Diepsloot West Street - a long stretch of road leading towards the river that runs through extension 2, was suitably positioned as a host venue and location for the installation of a possible linear sculpture concept. And given that much of the public realm works by City were centered on improved conditions for pedestrians, the extended sidewalks north and east of the school lent themselves to a street parade that would simultaneously orientate an audience to part of the upgrade area while aligning the narrative of the parade with educational and youth centered challenges in Diepsloot.



AUDITION! AUDITION! AUDITION! CALL TO DIEPSLOOT ARTISTS

Diepsloot Public Environment Upgrade: Public Art Commission Workshop

All experienced sculptors, painters and mosaic artists are invited to attend a 1 day show and tell workshop

Saturday 16 April 2011

**Muzomuhle School, Ext. 2 Next to Youth Centre
10am – 2pm**

This workshop will serve as an audition, where a small group of artists will be selected to work in collaboration with pupils from the Muzomuhle School, to develop a public artwork in proximity to the school.

Please bring a small portfolio of artworks to show your experience in the following media: drawing, painting, mural art, sculpture and mosaics.

Contact: Papi Sathekge (Chair DACN) - 076 023 0323



SEEING DIEPSLOOT THROUGH INTERGENERATIONAL EXCHANGE

Together with Sticky Situations and the Diepsloot Arts and Culture Network – workshop participants were identified through a publicly announced audition process, which enabled the sourcing of creatives from the township. The register developed through the audition process in turn informed the selection of participants for the concept development workshops that took place over a period of a week at Muzomuhle Primary School.

GENERATING THE NARRATIVE

The Township of Diepsloot was settled after 1994, as compared to the more historically well-known Townships of Johannesburg such as Alexandra or Soweto, whose social and cultural identities were forged through the colonial and apartheid eras of South Africa. Hence the identification of content, narratives of place and current conditions as well as ongoing challenges as experienced by residents became the focus for the project.

Given that Diepsloot sits far north on the periphery of greater Johannesburg, travel times and access to affordable and reliable transport are significant barriers to social and economic growth in addition the township is burdened by inconsistent delivery of electricity, water, sanitation housing and so on.

With these challenges affecting all residents in the area, it was critical that the workshop process harness the perspectives of various age groups living in Diepsloot through an intergenerational dialogue. The participants comprising 15 Muzomuhle learners and 15 adult residents from Extension 2, were introduced to various story-telling and visualization methods which would assist in the telling of their own stories of the township through small-scale drawings and models in various media.



By separating the workshop participants into smaller groups - combining a balance of adults and learners and introducing various tools for writing, drawing and modelling, the groups were set to share and compare stories of their lived experiences of Diepsloot.

Orientating oneself to the upgrade area, is essential for gaining an understanding of the potential scale and impact the artwork might have, and while doing so, getting a feel for qualities and characteristics that make up the experience of the site and place.

Hand painted sign writing is common in townships and often an income generating solution for people with additional artistic abilities. And given that the 'source code' if you will for the final artwork would be routed in a story line, the use of text within the artwork would be likely.





STORY

It's in the Jungle, all the wild animals are there Looking for a platform to be the king of the Jungle. And the conflict started when the rabbit, took the Castle Chair/seat, Then the lion became angry because he thought he should be king. While the lion is threatening the other animals, the elephant came in and he said he's so strong than any other animal, He can even throw the lion away. Then the rabbit came with the solution to say if we can run and see who is the fastest and the bird started complaining saying what will happen because he is flying, the fish is in the water, we cannot be able to join the race, so the rabbit said "so you cannot be the King"



Is where I come from

DIEPSLOOT

Aids in Africa
Africa, Africa My land Africa my people Africa is where I come from our brothers and sisters are dying are dying because of aids

Aids where do you come from from go where you belong you belong not in my country As a child where who love her Africa I am raising myself

Ma Africa it us obtain be faithful and remember aids is a killer condom is a Protector take care ma Africa

DEAR DIEPSLOOT

Here are my feelings about you: you make me love you when its mon - wed, but when its thur my feelings change about 104....

- I can only have a good time when I go to school and study at night but I can only study on Mondays and Wednesday.

Why you make me angry on Thursday & Fridays.. Diepsloot you part- too much and forget that I have to study, you play a lot of noise and a lot of music... I can't concentrate, so you see my love for you is only conditional.

Of the myriad stories shared through the week, two iconic narratives were selected by the workshop group, and these then became the focus for each team to upcycle through model making methods that responded to the linearity of the site and the strong metaphoric characterization presented in the stories.



DESIGN DEVELOPMENT IN THE WORKSHOP SPACE

The choice of two storylines allowed for a dynamic cross-pollination of ideas and debate around final messaging, and over time the various design responses helped to imagine the best sentiments in each text. Thinking at a three-dimensional level would thus involve a range of techniques that required the manipulation of materials to perform in specific sculptural and structural ways; small scale paper, board and wire constructions are translatable in engineering terms and provide participants with specific knowledge in assembling and presenting three dimensional concepts. Most importantly a poignant message that all participants identify with, provides continuity and focus during a short period of intensive creation that must also allow for deviation and experimentation at the same time.

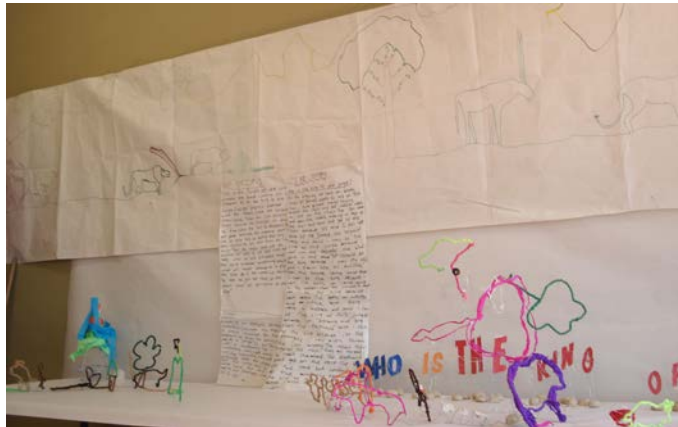
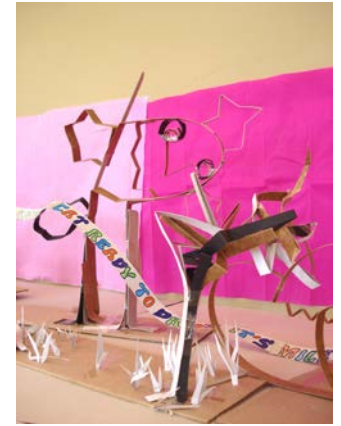
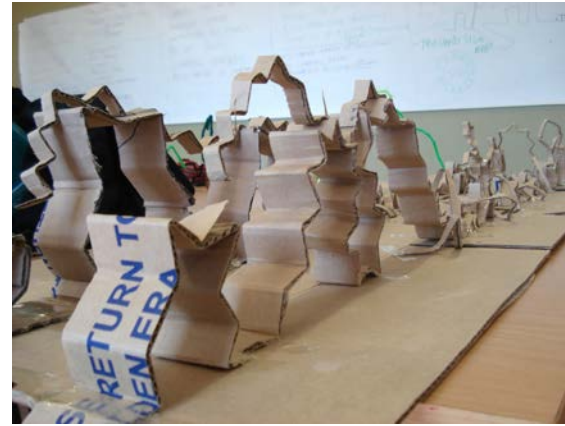

Select examples of the model making and linear composition in mixed media including; pipe cleaners, galvanized wire, paper, board and clay, glitter, buttons, etc.



The weeklong workshop process concluded with a presentation of various models that were consistent with the final storyline while illustrating the complexity of thinking and design possibilities. Learners were encouraged to comment and give feedback.



Due to a lack of key engineering skills in the area, the artworks programme sourced all technical, structural engineering and fabrication support from experienced suppliers in central Johannesburg. The Library Special Projects was brought on board early in the concept development phase in order to support and guide upcycling of the workshop models and design translation for implementation.

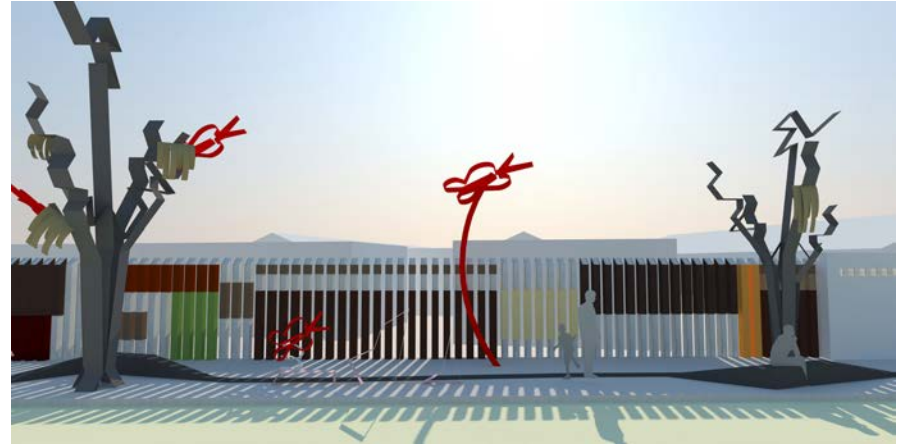

Hence the remarkable narrative-models presented at the end of the workshop process, provided sufficient evidence to client - that the basis for a linear sculpture was foreseeable and that the creation of a substantial street parade modelled on the concepts emerging from a story line highlighting a teenage girls struggles with nighttime learning in the township, resonates at a broad public level. It was further argued that the design development of the parade itself would provide useful documentation for the look and feel of a multi-part sculpture in the next financial year.



dear diepsloot,

from monday to wednesday, you make me love you like a
1 butterfly, that comes out of its cocoon.
I can only have a good time then, like a cat drinking its milk,
like a rabbit eating its carrots.

when it's thursday, my feelings change about you.
you turn into a pack of angry dogs.
you make me angry like a chicken whose chicks have been
taken away.

when it's thursday diepsloot, you act like a bunch of baboons.
you forget i need to hunt like an owl, searching for knowledge,
working at night.

when it's thursday diepsloot, you let my prey escape me.
dear diepsloot, i love you, but you break my heart.



CHARACTER DEVELOPMENT AND COSTUME DESIGN: all costume design elements were conceived through affordable found or recycled materials and were assembled by a collective of sewers and workshops participants under the creative guidance of the Diepsloot Arts and Culture Network Sticky Situations.



In the lead up to the parade, the Muzomuhle Primary School palisade fence underwent rehabilitation and a paint treatment that would serve as a finishing detail for the final sculptural installation, as well as allow for signage to communicate future planning to the local community.

DIEPSLOOT PUBLIC ENVIRONMENT ARTWORKS PROGRAMME

As part of the Diepsloot Public Environment upgrade this pedestrian walkway is to be complimented by a procession of public artworks conceived by the Muzomuhle School pupils and artists from the community. Generated in community based workshops, the artwork uses imagery of the animal kingdom to tell a story of the every-day struggles of life in Diepsloot.

In a community driven performance early in July the ideas generated by the workshop process are performed in a carnival-style street procession, produced by the Diepsloot Arts and Culture Network.

The public art installation is scheduled for completion in late 2011.

Commissioned by the Johannesburg Development Agency, and created by The Trinity Session, Sticky Situations, Diepsloot Arts and Culture Network and the Muzomuhle Primary School.

a world class African city

their displacement

From Monday to Wednesday you make me feel like a butterfly that cannot feel its content
I can only have a good time then, like a cat drinking its milk,
like a rabbit eating its carrots.

when it's Thursday, my feelings change about you,
you turn into a pack of angry dogs,
you make me cry like a child who thinks have been
taken away.

when it's Thursday I get you, you act like a bunch of balloons
you forget to burst like an ant searching for knowledge
waiting at night
when it's Thursday I get you, you let me cry escape me,
their displacement, I love you, but you break my heart.

The final installation. The fence will be painted in vibrant colors.



Diepsloot Arts and Culture Network Parade - *Diepsloot: I love you; I love you not.* July 2011



Diepsloot: I love you; I love you not finale outside the entrance to Muzomuhle Primary School

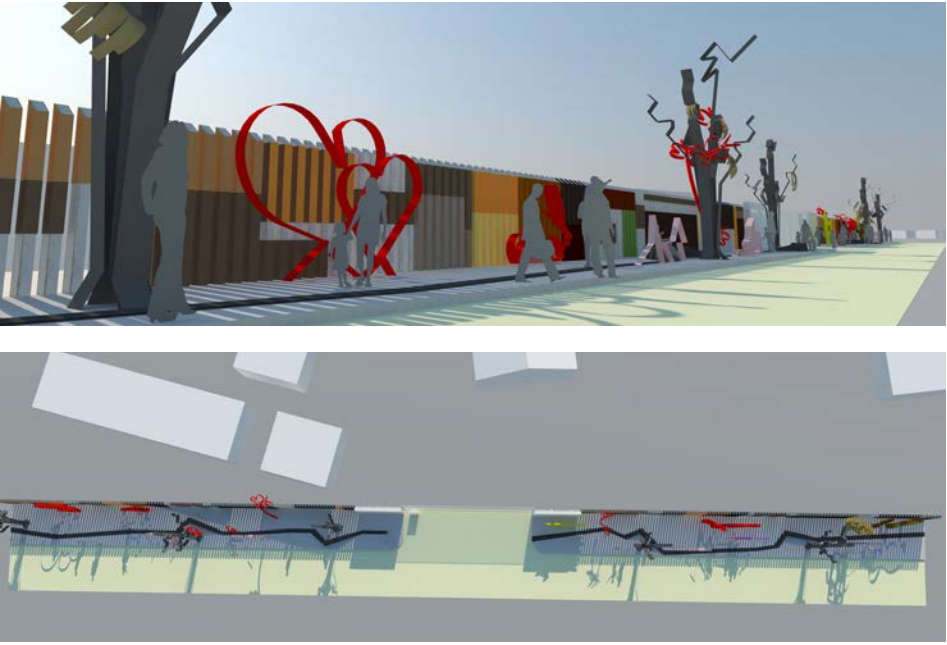
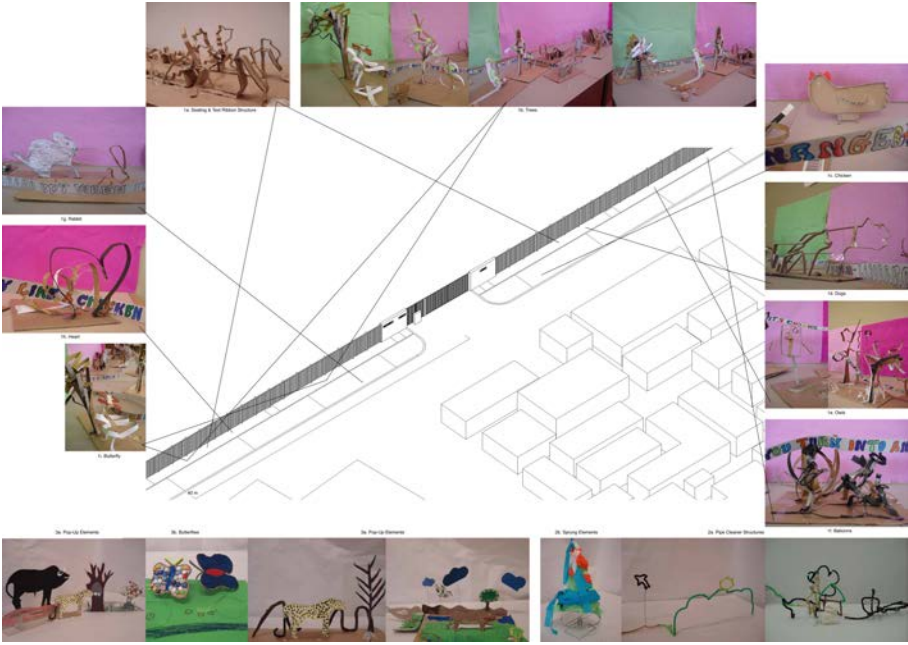

The Library Special Projects preliminary renders for presentation to the Johannesburg Agency Executive Committee

dear diepsloot,

from monday to wednesday, you make me love you like a

1 butterfly that comes out of its cocoon.

I can only have a good time then, like a cat drinking its milk,

like a rabbit eating its carrots.

when it's thursday, my feelings change about you.

you turn into a pack of angry dogs.

you make me angry like a chicken whose chicks have been

taken away.

when it's thursday diepsloot, you act like a bunch of baboons.

you forget i need to hunt like an owl, searching for knowledge,

working at night.

when it's thursday diepsloot, you let my prey escape me.

dear diepsloot, i love you, but you break my heart.

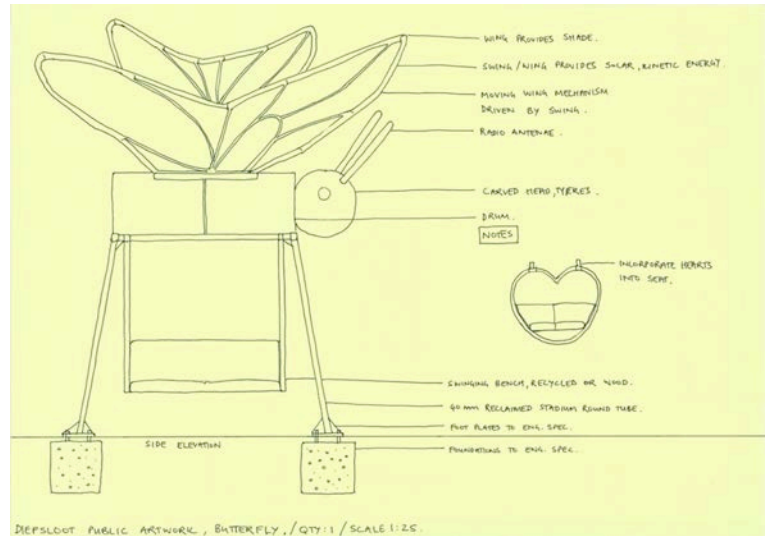
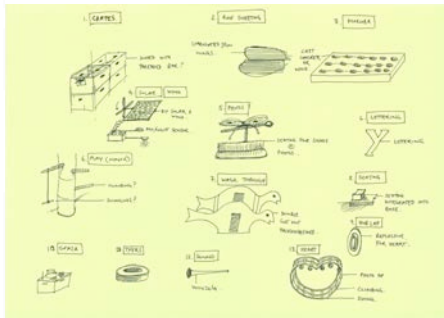
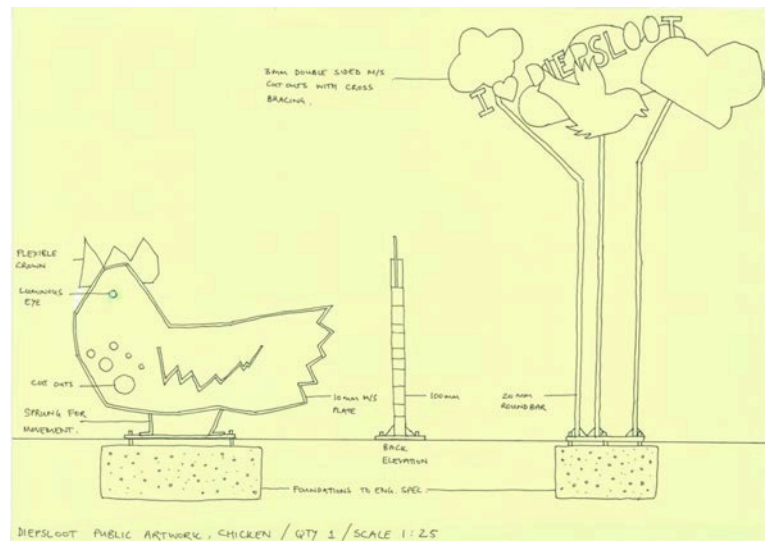
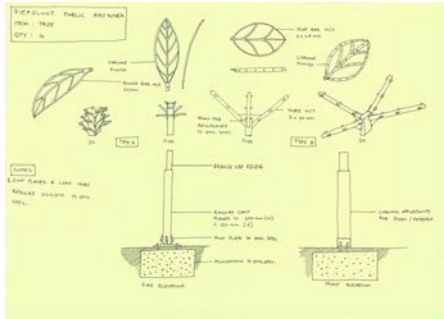
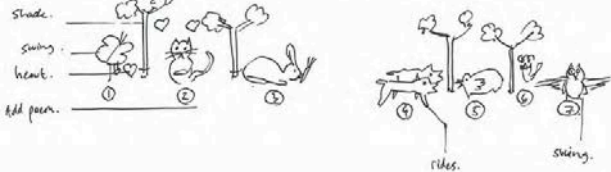

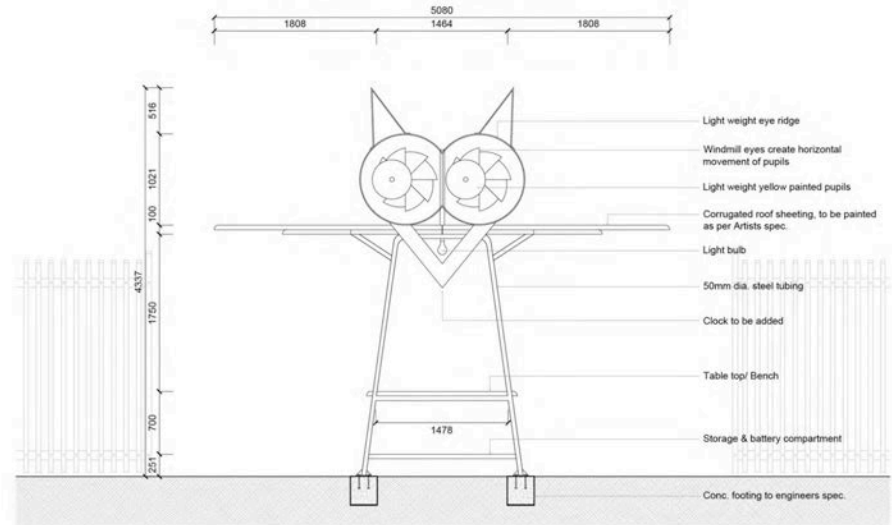
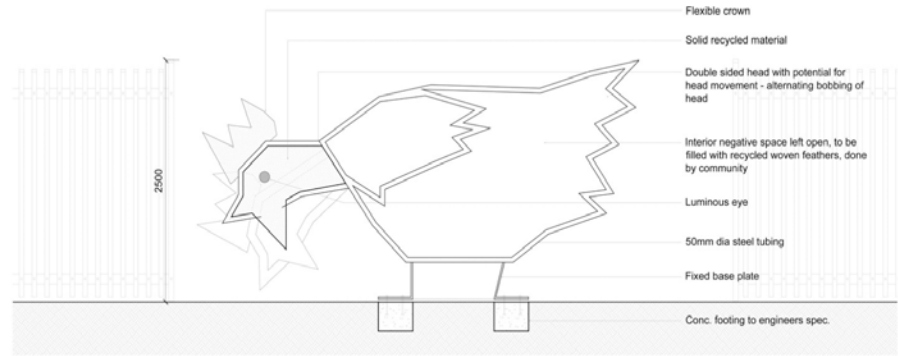

The Library Special Projects technical drawings for engineering input

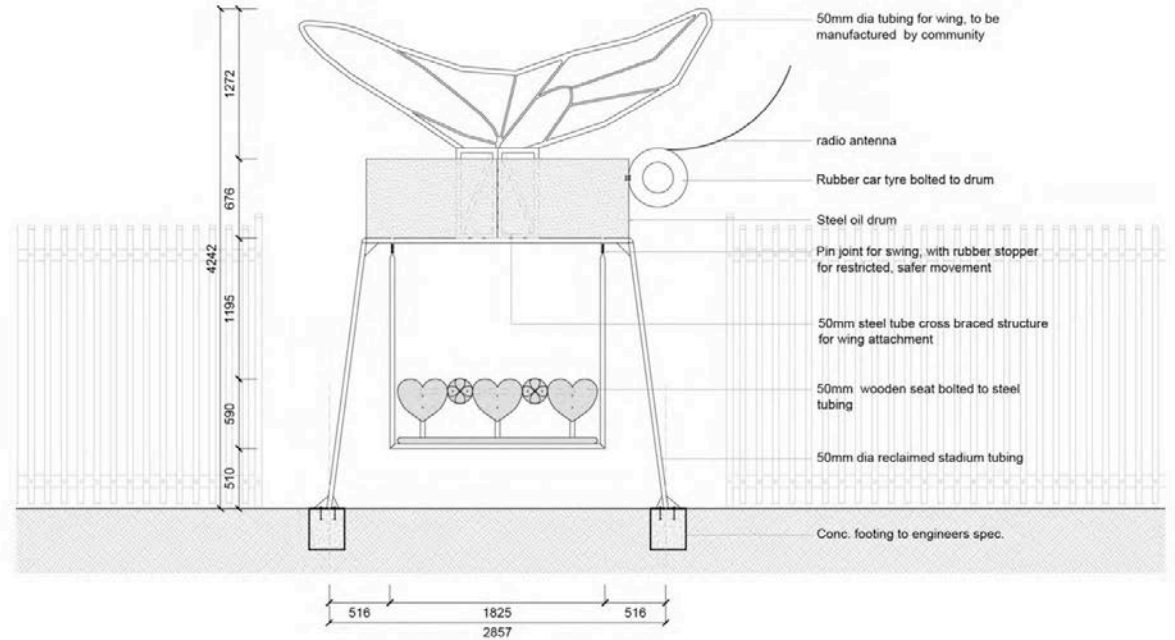

The Library Special Projects technical drawings for engineering input

DIEPSLOOT
WING TYPE: A - B

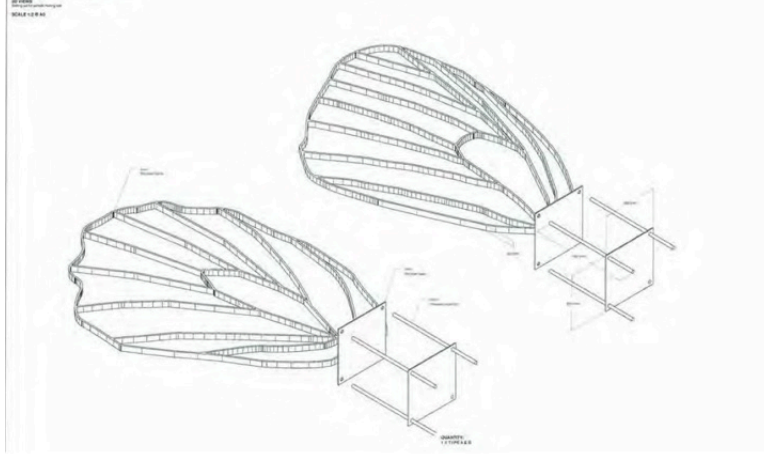

Preliminary modelling in steel - in collaboration with local metal worker



Final installation in progress

i ♥ you
i ♥ you not

dear diepsloot,

from monday to wednesday, you make me love you like a butterfly, that comes out of it's cocoon.

i can only have a good time then, like a cat drinking its milk,
like a rabbit eating its carrots.

when its thursday, my feelings change about you.

you turn into a pack of angry dogs.

you make me angry like a chicken whose chicks have been taken away.

when its thursday diepsloot, you act like a bunch of baboons.

you forget i need to hunt like an owl, searching for knowledge,
working at night.

when its thursday diepsloot, you let my prey escape me.

dear diepsloot, i love you, but you break my heart.



Diepsloot Public Environment Upgrade: Artwork Launch
18 November 2012, starts 11am
Skills Development Centre, Insonyama Drive, Diepsloot, Johannesburg

The poignance of the *Dear Diepsloot* poem gained a lot of attention through the parade in June 2011, encouraging word of mouth communication in the township, equally amongst urbanists, media and interested public that attended from central Johannesburg. The gaining momentum and appreciation behind the storyline and its purpose in guiding the final look and feel of the sculptural installation warranted a second performance to accompany the launch and closing of the project.



Diepsloot Arts and Culture Network Parade - *Diepsloot: I love you; I love you not.* 18 November 2012.

MMC Community Development, Clr. Chris Vondo

Some points on the City of Johannesburg's Public Art Programme and the Diepsloot performance

The City of Joburg, through the Joburg Development Agency as its implementation agent, has seen to the successful implementation of public art around greater Johannesburg for the past 10 years. The City believes that a successful public art programme improves the quality of an environment by making it a more attractive place to work or live, and that good public art generates a culture of creativity and helps to promote the image of an area. Public art should resonate with and have some impact on the site in which it is placed. The physical, social and historical character of a site provides critical information to the briefing of an artwork, which in order to remain relevant for a sustained period of time, needs to take into consideration the visible and invisible socio-political and cultural forces that surround it. Artists with unique skills, visions and creative talents have the ability to infuse our spaces and places with exactly such distinctive identities.

The main aims of the City of Joburg's Public Art Strategy in the medium term are:

- To build an interesting, diverse and high quality portfolio of public artworks for the City of Johannesburg by;

Commissioning and installing public art that:

- Creates interest in the public environment
- Supports the creation of a neighbourhood or area identity
- Serves as landmark, gateway or navigation element
- Improves the visual landscape in public space
- Records, communicates and celebrates historic events and people



The Diepsloot public art project has created an opportunity for local artists and schoolchildren to provide a window on the unique cultural and social environment in this area. Artists are often very well equipped to explore and articulate issues of local significance. Where there is a need for community involvement, artists are often used to engage with the community, as they can reach those who are often not represented through the normal channels such as tenants associations, committees etc. The Diepsloot performance – and the resulting permanent artworks – aims to be a representation of a concept or idea by the artists as much as a collective statement of a community about its own context. Socially researched and collectively produced work such as the Diepsloot programme is in line with the City’s Public Art Strategy, which aims to create collective ownership and support as well as skills transfer opportunities between established local creative practitioners and learners. The Diepsloot programme has also presented a new opportunity to align the artworks procurement process to a performative component, which is intended to inform the permanent artworks. The significance of procuring temporary and ephemeral work lies in that it enhances audience appreciation for the overall artworks project, and that it creates a far more comprehensive opportunity for community engagement in the shaping of the final pieces.

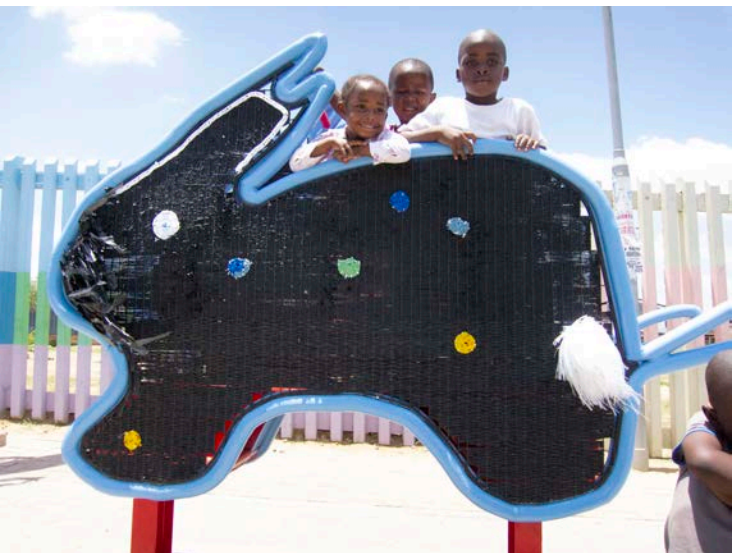

Diepsloot Street Performance: 2 July 2011

CAST

MC Papi Sethege
CHOIR MC Bernard Maulazi

MUZOMUHLE PRIMARY SCHOOL CHOIR

Soprano: Asisipho Ludidi, Jeanete Mthembu, Delisile Mthuli, Asisipho Konco, Asive Khalipha, Nkele Ramalatswo, Thulisile Mashaila, Zinzi Ndlovu, Anele Ntsele, Thokozile Gumbo, Zinhle Muleya, Vikeleni Dlamini, Consolia Sibanda, Lindi Khoza, Siphesihle Sikhakhane, Fortunate Sambo, Promise Kubheka, **Auto:** Johanna Mabaso, Nonhlanhla Hlongwane, Thembi Masemola, Bongwiwe Ndlela, Thulethu Nhose, Gugu Monye, Cebisile Ngidi, Jennifer Hlatshwayo, Patience Moyo, Phila Ndlovu, Zanele Khumalo, Pretty Mila, Busisiwe Thabede, Philiswa Mdlodlo, Lumka Nyaka, Sarah Mkhombo, Valentine Simelane, Maletsatsi Mahlatsi, **Tenor:** Phanal Gama, Luthando Mbasa, Benefit Mfundla, Themba Malinga, Thabiso Vilakasi, Thethelane Khumalo, Sthembiso Mthembu, Thobane Ngubane, Simphiwe Shabalala, David Dlamini, Nicolus Shabalala, Mgani Dube, Milton Manyisa, Fanie Skhulule, Gift Chisale, Msizi Ngubane, Thabiso Shoba, Mthokozisi Ngubane, Mandlenkosi Dlamini, Jefferey Gama, Thembelani Botha, Emmanuel Khumalo, Aviwe Khalipha, Mbongeni Makhaya, Ishmael Nkomo, Mlandeleni Zungu

BUTTERFLIES

Mpho Madubane, Sithandiwe Shusha
Lerato Masuke

RABBITS

Deliwe Malebye, Victor Musa, Nkosinathi Dube,
Simon Mahuma, Koketso Mashaba

CHICKENS

Lydia Mokwena, Lonah Kaleni, Wandile

CATS

Diana Mondli, Sihle Goso, Mercy Ndebele

OWLS

Innocent Manyathi

KNOWLEDGE

Thabiso Ramala, Siphonkosi

DOGS

Nathi Molisi, John Ramaphakela, Gugu Sibanyoni, Lorraine Monidi, Brian Flame

BABOONS

Thulani Mthiba, Kathago Mthobi,
Paul Maseho, Jackson Motaung

CREW

Creative Director: Papi Satege
Choreography: Lucky Nkali
Music Director: Bernard Mulauzi
Crew Director: Tony Ntsimane
Usher: Martin Mulauzi
Usher: Dan Maune
Usher: Thandiwe Nkgapele
Costume Creation: Genevieve Blanchett, Sticky Situations
Project Manager: Jennifer van den Bussche, Sticky Situations.

COSTUMES

Designer: Genevieve Blanchett
Design Assistant: Caroline Comino
Production: Malebo Moaele, Esther Mmako, Mirriam Thabane, Sylvia Sechwaro, Kelsey Tihosane, Thabo Motswana, Thabang, Edward Khoza, Brian Chitza, Phillip Phiri, Lucky Scharneck, Phillip Makwala, Clement Zaita.
Thanks to Moosa and Catherine

For Information contact:

Diepsloot Arts + Culture Network
Bernard 073 067 9299
mxomulauzi@gmail.com
Sticky Situations:
Jennifer 082 3677 806
jennifer@stickysituations.org

I ♥ YOU , I ♥ YOU NOT

The City of Johannesburg through its implementing agent, The Johannesburg Development Agency (JDA) has identified an upgrade area between the Taxi Rank and the Diepsloot River, running along Nkonyama Road, down King Mapuru Road passing the Muzomuhle Primary School. The upgrading of the Taxi Rank, with the addition of new ablution blocks, new paving, planting, urban furniture, and the erection of a new pedestrian bridge across the river in Ext 1, is to be complimented by a community driven performance on Saturday 2 July and public art installation scheduled for completion in October 2011.

The project is being implemented by the JDA and its artworks curator – coordinator, the Trinity Session with community based creative facilitation from Sticky Situations and the Diepsloot Arts and Culture Network.

“I Love You...I Love You Not” ---- PUBLIC ART via PERFORMANCE ART

“I Love You...I Love You Not” uses the imagery of the animal kingdom to tell a story of the every-day struggles of life in Diepsloot. Using a mix of song, dance and storytelling, the performance is a fun, carnival-style street procession that represents the collaborative effort of some of Diepsloot’s brightest creative talents, both young and old.

“I Love You...I Love You Not” is the innovative second-phase in the design process of a public artwork for Diepsloot as part of the JDA upgrading programme. The performance is a physical manifestation of the ideas generated in the first-phase community workshop, and will further develop the artwork’s design via the sculptural interaction of bodies within the site space outside Muzomuhle School.

“I Love You...I Love You Not” is being produced by the Diepsloot Arts and Culture Network, with cast, crew and creative teams being drawn from their extensive local networks as well as the pupils of the school itself.

This performance inspired by creative art workshop, participants: Lucky Scharneck, Monki Mtsweni, Phillip Phiri, Edward Khoza, Brian Isaac Chitsa, Johannes Mosena, Thulani Simelane, Silindile Shabangu, Fliex Simbine, Eva Ngwepe, Sthembiso Ngcongco, Esrom Masilo Raphela, Tlou Albert Mabotja, Tebogolo Louise Lefifi, Thandiwe Nkgapele, Elija Gqopo, Kelsey Tihosane, Maria Prudence Mohale Paul Kubiyana, Kgothatso Shurnell Lemao, Tebogolo Malatji, Johannes Mandlase, Charmain Maboya, Dineo Likasa, Busisiwe Thabede, Hlengiwe Simelane, Musa Mashiakgomo, Elsie Mamabolo

Welcome by :

- MMC, Community Development, Clr. Chris Vondo
- Mr Louis Baloyi, Department of Sports Culture and Heritage **tb**c
- Ward 95 Councillor, Rogers Makhubele
- Diepsloot Arts & Culture Network

Acknowledgements:

Muzomuhle Primary School welcomes the opportunity to host this event,
Diepsloot Arts & Culture Network [DACN],
Zizanani, Women's & Youth Empowerment and Digital Projects,
Ward 95 Councillor, Rodgers Makhubele.



a world class African city



the trinity session



STICKY SITUATIONS

BLACK BITE MEDIA PRODUCTIONS cc

BOZA'S KISHEN

DIEPSLOOT ARTS + CULTURE NETWORK PRESENTS

Arts in Action
Saturday 16th July
Youth Centre, Diepsloot.

For the third year, Diepsloot Arts in Action, an all day performance, will be showcasing talented artists of Diepsloot, including Theatre, Music, Dance (traditional and contemporary), Poetry and Storytelling.

For information contact:

Diepsloot Arts + Culture Network, Bernard 073 067 9299, mxomulauzi@gmail.com

i ♥ you
i ♥ you not

dear diepsloot,

from monday to wednesday, you make me love you like a butterfly, that comes out of it's cocoon.

i can only have a good time then, like a cat drinking its milk, like a rabbit eating its carrots.

when its thursday, my feelings change about you.

you turn into a pack of angry dogs.

you make me angry like a chicken whose chicks have been taken away.

when its thursday diepsloot, you act like a bunch of baboons. you forget i need to hunt like an owl, searching for knowledge, working at night.

when its thursday diepsloot, you let my prey escape me.

dear diepsloot, i love you, but you break my heart.

COMMUNITY

SHOW AND TELL

THE DIEPSLOOT COMMUNITY'S STORIES, DESIGNS AND HARD WORK ARE LAID BARE IN AN ACCESSIBLE PUBLIC ARTWORK

TEXT: DIANE CORTZER PHOTOGRAPHY: CHRIS SAUNDERS

IT STARTED WITH A POEM, ONE THAT meaningfully captures the highs and lows of township life for a kid who's just trying to get through homework and life.

"Dear Diepsloot," the poem begins, "From Monday to Wednesday, you make me love you like a butterfly, that comes out of its cocoon... Where it's Thursday, Diepsloot, you are like a bunch of bad boys who forget to read but love the art reel, searching for know-how, working at night."

"This piece of writing, titled *I Love You / I Love You Not*, written by young artist Bheumane Ngqopho and developed with learners from Muzumuhle Primary School in Diepsloot and local artists, proved to be the catalyst for a public art project — the Diepsloot Public Artworks Programme — that has not only seen the

Johannesburg Development Agency (JDA) win this year's BASA Increasing Access to the Arts Award, but has significantly affected how public art is created within communities in the city.

For the first time in the JDA's extensive public art initiative, the evolution of the Diepsloot Public Artworks Programme drew on the vibrant performing arts scene that's an integral part of this impoverished township.

"Henceforth, the JDA deserves to win a BASA award for this," says Stephen Hobbs, co-director of The Trinity Session, which has worked with the JDA on many other public art projects including the BASA award-winning Rea Vaya Bus Rapid Transit Station Public Art project.

"With this particular project and in this sector, the JDA has proved to be bold and courageous."

Hobbs knew it intimately the challenges of getting to the projects and results — a pavement bristling with colonialist, large-scale sculptures outside Muzumuhle Primary School that are made with locally sourced recycled materials and are images from the animal kingdom used a story of everyday life in the area.

The Trinity Session was appointed curator and coordinator for the JDA's public art programme for three years, ending in June this year. To implement the Diepsloot Public Artworks Programme, the Johannesburg-based Company founded by Hobbs and Monica Neumeister worked with the JDA, Sticky Situations (which contributed community-based creative facilitators) and the Diepsloot Arts and Culture Network.

"The programme formed part of the JDA's public



COMMUNITY



Diepsloot I love you / I love you not

environment upgrading in Diepsloot that included a taxi rank, new pedestrian bridges and pathways. It made use of the JDA's ongoing commitment to spend up to 1% of all projects of over R10m on public art.

For Hobbs and the rest of the partners, the most important starting point for the Diepsloot Public Artworks Programme was ensuring the highest level of community participation and engagement as possible.

"Through the many public art programmes that we've curated and co-ordinated, we know how to broker, on behalf of the city, with artists on a large scale," Hobbs explains.

"We also have a lot of experience in engaging people, in participation. In the end the public art that is created is a capital asset of the city and so integrating community participation and ownership upfront is vital."

In the case of the Diepsloot Public Artworks Programme, community involvement came first

with the stories of ordinary Diepsloot residents and learners, on how they felt about living in the township. The poem that emerged out of that workshop process fed into the culmination of the first phase of the development: the 2011 annual Diepsloot Arts in Action Festival, which used performance (song, dance and storytelling) to relate the overall theme of the project, *I Love You... I Love You Not*, to the community.

Creating opportunities for artists in the area is important to the JDA's Public Art Policy, says Hobbs, and given the strong presence of performance artists in Diepsloot their inclusion in the 2011 event and in the final unveiling of the sculptures in November last year (through a performance co-ordinated by the Diepsloot Art and Culture Network) was essential.

Further community involvement came in multiple ways: community workshops to refine the design of the sculptures, partnerships with recyclers in Diepsloot, workshops with the

schoolchildren at Muzumuhle Primary School to teach them how to make flowers out of bottles, paper and cans and support for local artists and artisans who made the sculptures, including several outside artists teaching new techniques, such as weaving with recycled materials.

"All of this was an important way of taking the poem and one or two other stories and starting to construct sculptural interpretations of the texts," says Hobbs.

The result is now an award-winning public artwork that celebrates Diepsloot's diversity and culture — and, in the case of some of the sculptures, is even used by its children as play equipment.

"Relatively speaking, the amount of effort and energy that has gone into public art with the Diepsloot Public Artworks Programme is positioning Johannesburg at the vanguard edge of this work in SA," Hobbs states emphatically.

Diepsloot Arts, diepslootarts.org



In the end the public art that is created is a capital asset of the city and so integrating community participation and ownership upfront is vital

14 | AUGUST 2013 | WANTED



Diepsloot Public Artworks Programme

Photograph by Richard Hobbs

The Johannesburg Development Agency (JDA) implemented a public art project in Diepsloot as part of public environment upgrade work they undertook to develop this neighbourhood on behalf of the City of Johannesburg.

With its involvement in the Diepsloot Development an opportunity was presented to work with the community and local artists to produce a public art installation that had strong social references to the community of Diepsloot.

Trinity Session, the JDA's public artworks curator, with the help of the Diepsloot Arts and Culture Network, The Library and Sticky Situations, ran workshops that resulted in a poem that was the inspiration behind the design for a series of sculptures in Diepsloot.

The poem evolved from a love letter to Diepsloot, written by young artist Thandwe Nkigapele, which was workshoped with learners from Muzomhle Primary School and local artists, and turned into a poem reflecting the every day struggles of life in Diepsloot.

I love you...I love you not

DEAR DIEPSLOOT,

From Monday to Wednesday, you make me love you like a butterfly that comes out of its cocoon.

I can only have a good time then, like a cat drinking its milk, like a rabbit eating its carrots.

When it's Thursday, my feelings change about you. You turn into a pack of angry dogs.

You make me angry like a chicken whose chicks have been taken away.

When it's Thursday Diepsloot, you act like a bunch of baboons.

You forget I need to hunt like an owl, searching for knowledge, working at night.

When it's Thursday Diepsloot, you let my prey escape me.

DEAR DIEPSLOOT, I LOVE YOU, BUT YOU BREAK MY HEART.

This poem inspired the sculptures which double up as play equipment for children in the area. The Diepsloot Arts and Culture Network (DACN), choreographed a performance art that launched the artworks programme to much fanfare. DACN is a not-for-profit organisation that was established and proudly belongs to the artists of Diepsloot. DACN sources opportunities and employment for all Diepsloot artists, drawing on both young and old talents to enhance their livelihood prospects.

DACN supported the public art project by facilitating local artists involvement in the conceptualisation and design of the sculptures. They also participated in producing costumes and staging a street festival that engaged the community in the design process.

During the production of the sculptures, DACN members were integrally involved in creating the decorative elements in the sculptures through recycled materials. Finally, the DACN was a key partner in celebrating the launch of the artwork with a musical and theatrical performance.

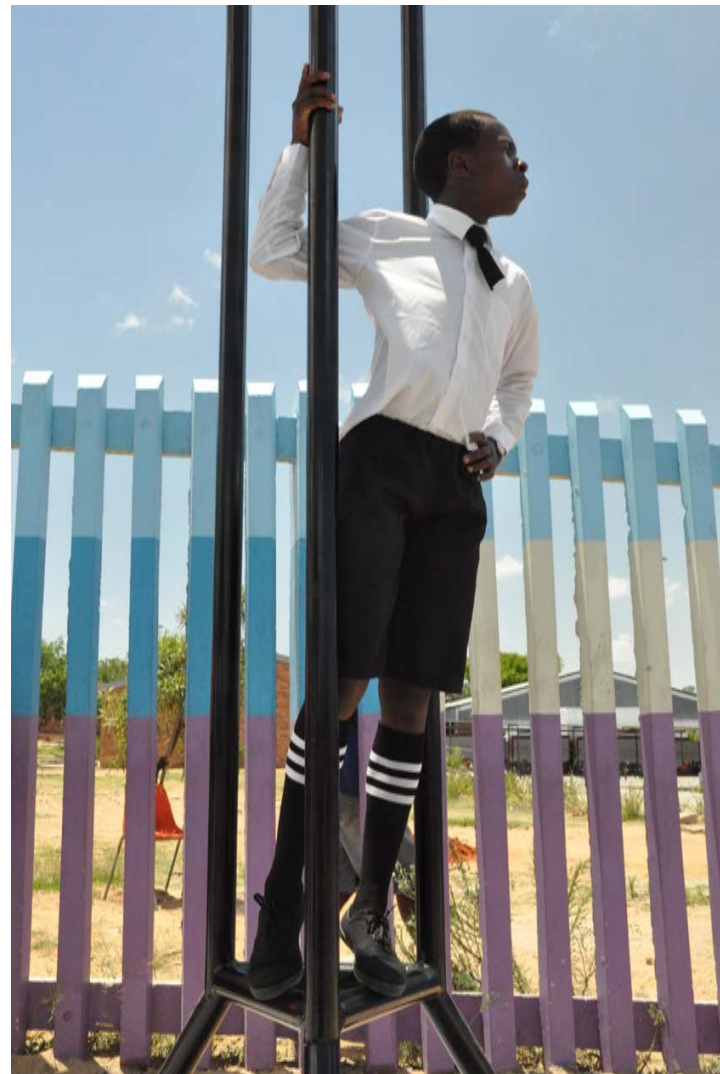

a world class African city



City of Johannesburg
Johannesburg Development Agency

The Bus Factory
No. 3 President Street
Newtown
Johannesburg

PO Box 61877
Marshalltown
Johannesburg
2107

Tel +27(0) 11 688 7851
Fax +27(0) 11 688 7899
www.jda.org.za
www.joburg.org.za